

HIGH PERFORMANCE DIFFERENTIAL OSCILLATOR SERIES „DLPO-1“ 1.0—220. MHz

FEATURES

- + 100% pin-to-pin drop-in replacement to quartz and MEMS based XO
- + Differential Oscillator for Low Cost
- + Low Power Consumption / ST option for reducing power consumption
- + Extremely low RMS jitter
- + Excellent long time reliability
- + LVCMOS, LVPECL, LVDS, HCSSL, CML output signal
- + Very tight frequency stability as low as ± 10 ppm possible
- + Outstanding long term aging
- + Supply voltage 1.8, 2.5 or 3.3V—others, please contact us
- + Industry-standard packages: 5.0x3.2; 7.0x5.0 mm
- + Pb-free, RoHS and REACH compliant / MSL1@260°C

APPLICATIONS

- + Server, Router, RAID controller
- + Gigabit Ethernet, 10 Gigabit Ethernet, Fiber Channel
- + SATA / SAS, PCI-Express, Fully Buffered DIMM
- + System clock, Networking and computing
- + etc.

PIN DESCRIPTION

PIN	SYMBOL		FUNCTIONALITY
1	ST/OE	Input	Standby or Output Enable pin for OUT+ and OUT-. OE: When High or Open : OUT+ and OUT- = active When Low : OUT+ and OUT- = High Impedance state ST: When High or Open : OUT+ and OUT- = active When Low : OUT+ and OUT- = Output is low (weak pull down), oscillation stops
2	NC	NA	Do Not connect pin, leave it floating.
3	GND	Power	VDD power supply ground. Connect to Ground
4	OUT+	Output	1 to 220 MHz programmable clock output.
5	OUT-	Output	
6	VDD	Power	Power Supply Voltage

TOP VIEW

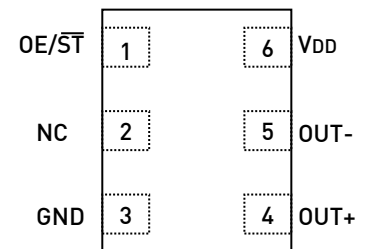

DC ELECTRICAL SPECIFICATIONS

LVCMOS input, OE or ST pin, 3.3V ±10% or 2.5V ±10% or 1.8V ±5%, -40 to 85°C

PARAMETER	SYMBOL	MIN.	Typ.	Max.	Unit	CONDITION
Input High Voltage	V _{IH}	70	-	-	%VDD	
Input Low Voltage	V _{IL}	-	-	30	%VDD	
Input High Current	I _{IH}	-	-	10	µA	OE or ST pin
Input Low Current	I _{IL}	-10	-	-	µA	OE or ST pin
Power Up Time	T _{pu}	-	-	10	ms	Time from minimum power supply voltage to the first cycle (Guaranteed no runt pulses)

LVPECL Output, 3.3V ±10% or 2.5V ±10%, -40 to 85°C

PARAMETER	SYMBOL	MIN.	TYP.	MAX.	UNIT	CONDITION
Supply Voltage	VDD	2.97	3.3	3.63	V	
		2.25	2.5	2.75	V	
Supply Current	IDD	-	68	74	mA	VDD = 3.3, Excluding Load Termination Current
		-	65	71	mA	VDD = 2.5, Excluding Load Termination Current
Output High Voltage	V _{OH}	VDD-1.1	-	VDD-0.7	V	50 Ohm termination to VDD - 2.0V See Figure 2, 3.
Output Low Voltage	V _{OL}	VDD-2.0	-	VDD-1.4	V	
Pk-Pk Output Voltage Swing	V _{swing}	600	800	1000	mV	

HCSL, 3.3V ±10% or 2.5V ±10%, -40 to 85°C

PARAMETER	SYMBOL	MIN.	TYP.	MAX.	UNIT	CONDITION
Supply Voltage	VDD	2.97	3.3	3.63	V	
		2.25	2.5	2.75	V	
Supply Current	IDD	-	65	70	mA	VDD = 3.3, Excluding Load Termination Current
		-	62	67	mA	VDD = 2.5, Excluding Load Termination Current
Output High Voltage	V _{OH}	600	-	950	V	50 Ohm termination to GND Figure 4.
Output Low Voltage	V _{OL}	0.0	-	50	V	
Pk-Pk Output Voltage Swing	V _{swing}	600	-	950	mV	

DC ELECTRICAL SPECIFICATIONS

LVDS, 3.3V ±10% or 2.5V ±10%, -40 to 85°C

PARAMETER	SYMBOL	MIN.	TYP.	MAX.	UNIT	CONDITION
Supply Voltage	VDD	2.97	3.3	3.63	V	
		2.25	2.5	2.75	V	
Supply Current	IDD	-	73	79	mA	VDD = 3.3, Excluding Load Termination Current
		-	70	76	mA	VDD = 2.5, Excluding Load Termination Current
Differential Output Voltage	V _{OD1}	250	350	450	mV	Swing Mode = Normal Single load termination. See Figure 5.
V _{OD} Magnitude Change	ΔV _{OD1}	-	-	50	mV	
Offset Voltage	V _{OS1}	-	1.2	-	V	
V _{OS} Magnitude Change	ΔV _{OS1}	-	-	50	mV	
Differential Output Voltage	V _{OD2}	500	700	900	mV	Swing Mode = High Single load termination. See Figure 5.
V _{OD} Magnitude Change	ΔV _{OD2}	-	-	50	mV	
Offset Voltage	V _{OS2}	-	1.2	-	V	
V _{OS} Magnitude Change	ΔV _{OS2}	-	-	50	mV	
Differential Output Voltage	V _{OD3}	250	350	450	mV	Swing Mode = High Double load termination. See Figure 6
V _{OD} Magnitude Change	ΔV _{OD3}	-	-	50	mV	
Offset Voltage	V _{OS3}	-	1.2	-	V	
V _{OS} Magnitude Change	ΔV _{OS3}	-	-	50	mV	

CML, 3.3V ±10% or 2.5V ±10% or 1.8V ±5%, -40 to 85°C

PARAMETER	SYMBOL	MIN.	TYP.	MAX.	UNIT	CONDITION
Supply Voltage	VDD	2.97	3.3	3.63	V	
		2.25	2.5	2.75	V	
		1.71	1.8	1.89	V	
Supply Current	IDD	-	48	51	mA	VDD = 3.3V
		-	47	50	mA	VDD = 2.5V
		-	38	41	mA	VDD = 1.8V
Output High Voltage	V _{OH1}	VDD ^{-0.1}	-	VDD	V	Swing Mode = Normal Single Load Termination See Figure 7.
Output Low Voltage	V _{OL1}	VDD ^{-0.55}	VDD ^{-0.425}	VDD ^{-0.3}	V	
Pk-Pk Output Voltage Swing	V _{swing1}	300	425	550	mV	
Output High Voltage	V _{OH2}	VDD ^{-0.1}	-	VDD	V	Swing Mode = High Single Load Termination See Figure 7.
Output Low Voltage	V _{OL2}	VDD ^{-1.1}	VDD ^{-0.85}	VDD ^{-0.6}	V	
Pk-Pk Output Voltage Swing	V _{swing2}	600	850	1100	mV	
Output High Voltage	V _{OH3}	VDD ^{-0.1}	-	VDD	V	Swing Mode = High Double Load Termination See Figure 8.
Output Low Voltage	V _{OL3}	VDD ^{-0.55}	VDD ^{-0.425}	VDD ^{-0.3}	V	
Pk-Pk Output Voltage Swing	V _{swing3}	300	425	550	mV	

AC ELECTRICAL SPECIFICATIONS

LVPECL, 3.3V ±10%, -40 to 85°C

PARAMETER	SYMBOL	MIN.	TYP.	MAX.	UNIT	CONDITION
Output Frequency	F _{out}	1.0	-	220	MHz	
Frequency Stability	F _{stab}	-10	-	+10	PPM	Inclusive of initial stability, operating temp., rated power supply voltage change, load change
		-15	-	+15	PPM	
		-20	-	+20	PPM	
		-25	-	+25	PPM	
		-50	-	+50	PPM	
Aging	F _{age}	-	-	1	PPM	First year @ 25°C
Duty Cycle	DC	45	-	55	%	
Output Rise/Fall Time	t _r /t _f	100	150	300	ps	20% to 80%
RMS Phase Jitter (random)	PH _j	-	1.6	-	ps	F _{out} = 106.25 MHz @ BW: 637 kHz to 10 MHz
		-	0.5	-	ps	F _{out} = 156.25 MHz @ BW: 1.875 to 20 MHz
		-	0.7	-	ps	F _{out} = 200 MHz @ BW: 1 to 20 MHz
RMS Period Jitter	P _J	-	1.8	2.3	ps	F _{out} = 106.25 MHz
		-	1.3	1.8	ps	F _{out} = 156.25 MHz
		-	1.3	1.8	ps	F _{out} = 200 MHz

LVPECL, 2.5V ±10%, -40 to 85°C

PARAMETER	SYMBOL	MIN.	TYP.	MAX.	UNIT	CONDITION
Output Frequency	F _{out}	1.0	-	220	MHz	
Frequency Stability	F _{stab}	-10	-	+10	PPM	Inclusive of initial stability, operating temp., rated power supply voltage change, load change
		-15	-	+15	PPM	
		-20	-	+20	PPM	
		-25	-	+25	PPM	
		-50	-	+50	PPM	
Aging	F _{age}	-	-	1	PPM	First year @ 25°C
Duty Cycle	DC	45	-	55	%	
Output Rise/Fall Time	t _r /t _f	100	150	300	ps	20% to 80%
RMS Phase Jitter (random)	PH _j	-	1.6	-	ps	F _{out} = 106.25 MHz @ BW: 637 kHz to 10 MHz
		-	0.5	-	ps	F _{out} = 156.25 MHz @ BW: 1.875 to 20 MHz
		-	0.7	-	ps	F _{out} = 200 MHz @ BW: 1 to 20 MHz
RMS Period Jitter	P _J	-	1.8	2.3	ps	F _{out} = 106.25 MHz
		-	1.3	1.8	ps	F _{out} = 156.25 MHz
		-	1.3	1.8	ps	F _{out} = 200 MHz

AC ELECTRICAL SPECIFICATIONS

HCSSL, 3.3V ±10%, -40 to 85°C

PARAMETER	SYMBOL	MIN.	TYP.	MAX.	UNIT	CONDITION	
Output Frequency	F _{out}	1	-	220	MHz		
Frequency Stability	F _{stab}	-10	-	+10	PPM	Inclusive of initial stability, operating temp., rated power supply voltage change, load change	0 to 70°C -20 to 70°C -40 to 85°C
		-15	-	+15	PPM		
		-20	-	+20	PPM		
		-25	-	+25	PPM		
		-50	-	+50	PPM		
Aging	F _{age}	-	-	1	PPM	First year @ 25°C	
Duty Cycle	DC	45	-	55	%		
Output Rise/Fall Time	t _R /t _F	200	280	375	ps		
RMS Phase Jitter (random)	PH _J	-	0.8	-	ps	F _{out} = 100 MHz @ BW: 1.5 MHz to 22 MHz	
		-	0.4	-	ps	F _{out} = 200 MHz @ BW: 1.5 MHz to 22 MHz	
RMS Period Jitter	P _J	-	1.6	2.2	ps	F _{out} = 100 MHz	
		-	1.5	1.9	ps	F _{out} = 200 MHz	

HCSSL, 2.5V ±10%, -40 to 85°C

PARAMETER	SYMBOL	MIN.	TYP.	MAX.	UNIT	CONDITION	
Output Frequency	F _{out}	1	-	220	MHz		
Frequency Stability	F _{stab}	-10	-	+10	PPM	Inclusive of initial stability, operating temp., rated power supply voltage change, load change	0 to 70°C -20 to 70°C -40 to 85°C
		-15	-	+15	PPM		
		-20	-	+20	PPM		
		-25	-	+25	PPM		
		-50	-	+50	PPM		
Aging	F _{age}	-	-	1	PPM	First year @ 25°C	
Duty Cycle	DC	45	-	55	%		
Output Rise/Fall Time	t _R /t _F	200	300	400	ps	20% to 80%	
RMS Phase Jitter (random)	PH _J	-	0.8	-	ps	F _{out} = 100 MHz @ BW: 1.5 MHz to 22 MHz	
		-	0.4	-	ps	F _{out} = 200 MHz @ BW: 1.5 MHz to 22 MHz	
RMS Period Jitter	P _J	-	1.6	2.2	ps	F _{out} = 100 MHz	
		-	1.5	2.1	ps	F _{out} = 200 MHz	

LVDS , 3.3V ±10%, -40 to 85°C

PARAMETER	SYMBOL	MIN.	TYP.	MAX.	UNIT	CONDITION	
Output Frequency	F _{out}	10	-	220	MHz		
Frequency Stability	F _{stab}	-10	-	+10	PPM	Inclusive of initial stability, operating temp., rated power supply voltage change, load change	0 to 70°C -20 to 70°C -40 to 85°C
		-15	-	+15	PPM		
		-20	-	+20	PPM		
		-25	-	+25	PPM		
		-50	-	+50	PPM		
Aging	F _{age}	-	-	1	PPM	First year @ 25°C	
Duty Cycle	DC	45	-	55	%		
Output Rise/Fall Time	t _R /t _F	100	200	325	ps	20% to 80%	
RMS Phase Jitter (random)	PH _J	-	1.7	-	ps	F _{out} = 106.25 MHz @ BW: 637 kHz to 10 MHz	
		-	0.7	-	ps	F _{out} = 156.5 MHz @ BW: 1.875M Hz to 10 MHz	
		-	0.7	-	ps	F _{out} = 200 MHz @ BW: 1 to 20 MHz	
RMS Period Jitter	P _J	-	2	2.7	ps	F _{out} = 106.25 MHz	
		-	1.8	2.5	ps	F _{out} = 156.25 MHz	
		-	1.8	2.5	ps	F _{out} = 200 MHz	

AC ELECTRICAL SPECIFICATIONS

LVDS, 2.5V ±10%, -40 to 85°C

PARAMETER	SYMBOL	MIN.	TYP.	MAX.	UNIT	CONDITION
Output Frequency	F _{out}	1.0	-	220	MHz	
Frequency Stability	F _{stab}	-10	-	+10	PPM	Inclusive of initial stability, operating temp., rated power supply voltage change, load change
		-15	-	+15	PPM	
		-20	-	+20	PPM	
		-25	-	+25	PPM	
		-50	-	+50	PPM	
Aging	F _{age}	-	-	1	PPM	First year @ 25°C
Duty Cycle	DC	45	-	55	%	
Output Rise/Fall Time	t _r /t _f	100	260	325	ps	20% to 80%
RMS Phase Jitter (random)	PH _j	-	1.7	-	ps	F _{out} = 106.25 MHz @ BW: 637 kHz to 10 MHz
		-	0.7	-	ps	F _{out} = 156.25 MHz @ BW: 1.875 to 20 MHz
		-	0.7	-	ps	F _{out} = 200 MHz @ BW: 1 to 20 MHz
RMS Period Jitter	P _J	-	2.5	3.3	ps	F _{out} = 106.25 MHz
		-	2.4	3.5	ps	F _{out} = 156.25 MHz
		-	2.4	3.5	ps	F _{out} = 200 MHz

CML, 3.3V ±10%, -40 to 85°C

PARAMETER	SYMBOL	MIN.	TYP.	MAX.	UNIT	CONDITION
Output Frequency	F _{out}	1.0	-	220	MHz	
Frequency Stability	F _{stab}	-10	-	+10	PPM	Inclusive of initial stability, operating temp., rated power supply voltage change, load change
		-15	-	+15	PPM	
		-20	-	+20	PPM	
		-25	-	+25	PPM	
		-50	-	+50	PPM	
Aging	F _{age}	-	-	1	PPM	First year @ 25°C
Duty Cycle	DC	45	-	55	%	
Output Rise/Fall Time	t _r /t _f	150	220	300	ps	20% to 80%
RMS Phase Jitter (random)	PH _j	-	1.6	-	ps	F _{out} = 106.25 MHz @ BW: 637 kHz to 10 MHz
		-	0.6	-	ps	F _{out} = 156.25 MHz @ BW: 1.875 to 20 MHz
		-	0.8	-	ps	F _{out} = 200 MHz @ BW: 1 to 20 MHz
RMS Period Jitter	P _J	-	2	2.5	ps	F _{out} = 106.25 MHz
		-	1.9	2.5	ps	F _{out} = 156.25 MHz
		-	1.9	3.4	ps	F _{out} = 200 MHz

AC ELECTRICAL SPECIFICATIONS

CML, 2.5V ±10%, -40 to 85°C

Parameter	Symbol	Min.	Typ.	Max.	Unit	Condition
Output Frequency	F _{out}	1.0	-	220	MHz	
Frequency Stability	F _{stab}	-10	-	+10	PPM	Inclusive of initial stability, operating temp., rated power supply voltage change, load change
		-15	-	+15	PPM	
		-20	-	+20	PPM	
		-25	-	+25	PPM	
		-50	-	+50	PPM	
Aging	F _{age}	-	-	1	PPM	First year @ 25°C
Duty Cycle	DC	45	-	55	%	
Output Rise/Fall Time	t _r /t _f	150	230	300	ps	20% to 80%
RMS Phase Jitter (random)	PH _j	-	1.6	-	ps	F _{out} = 106.25 MHz @ BW: 637 kHz to 10 MHz
		-	0.6	-	ps	F _{out} = 156.25 MHz @ BW: 1.875 to 20 MHz
		-	0.8	-	ps	F _{out} = 200 MHz @ BW: 1 to 20 MHz
RMS Period Jitter	P _J	-	2.1	2.5	ps	F _{out} = 106.25 MHz
		-	1.9	2.5	ps	F _{out} = 156.25 MHz
		-	1.9	2.5	ps	F _{out} = 200 MHz

CML, 1.8V ±5%, -40 to 85°C

Parameter	Symbol	Min.	Typ.	Max.	Unit	Condition
Output Frequency	F _{out}	1.0	-	220	MHz	
Frequency Stability	F _{stab}	-10	-	+10	PPM	Inclusive of initial stability, operating temp., rated power supply voltage change, load change
		-15	-	+15	PPM	
		-20	-	+20	PPM	
		-25	-	+25	PPM	
		-50	-	+50	PPM	
Aging	F _{age}	-	-	1	PPM	First year @ 25°C
Duty Cycle	DC	45	-	55	%	
Output Rise/Fall Time	t _r /t _f	150	240	325	ps	20% to 80%
RMS Phase Jitter (random)	PH _j	-	1.7	-	ps	F _{out} = 106.25 MHz @ BW: 637 kHz to 10 MHz
		-	0.6	-	ps	F _{out} = 156.25 MHz @ BW: 1.875 to 20 MHz
		-	0.8	-	ps	F _{out} = 200 MHz @ BW: 1 to 20 MHz
RMS Period Jitter	P _J	-	2.3	2.9	ps	F _{out} = 106.25 MHz
		-	2.1	2.7	ps	F _{out} = 156.25 MHz
		-	2.1	2.7	ps	F _{out} = 200 MHz

TERMINATION DIAGRAMS

FIGURE 1. LVPECL AC COUPLED TYPICAL TERMINATION (LVPECL-0)

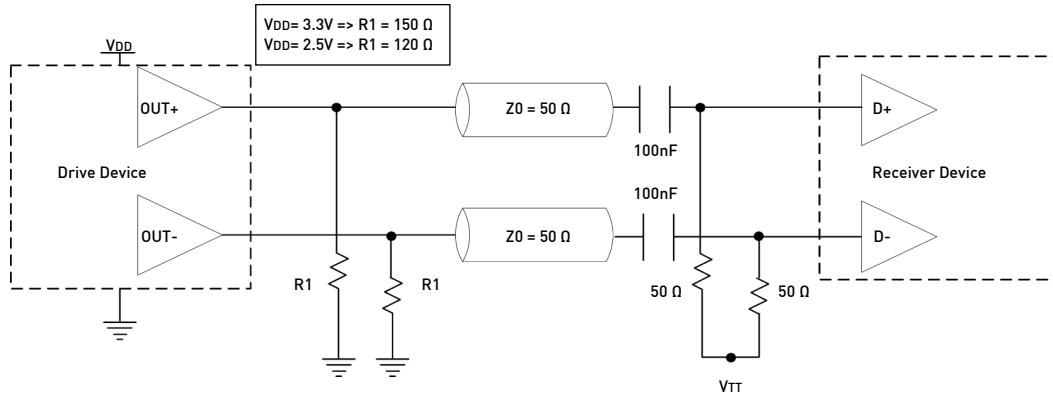

FIGURE 2. LVPECL DC COUPLED TYPICAL TERMINATION WITH TERMINATION VOLTAGE (LVPECL-1)

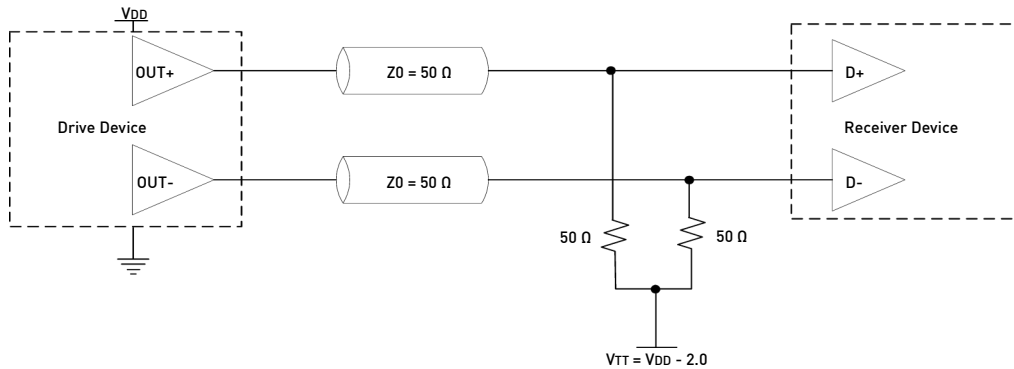
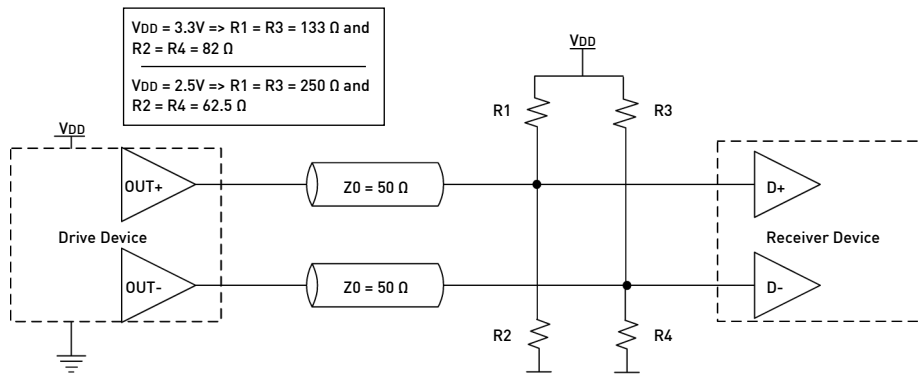

FIGURE 3. LVPECL DC COUPLED TYPICAL TERMINATION WITHOUT TERMINATION VOLTAGE (LVPECL-1)



TERMINATION DIAGRAMS

FIGURE 4. HCSL TYPICAL TERMINATION

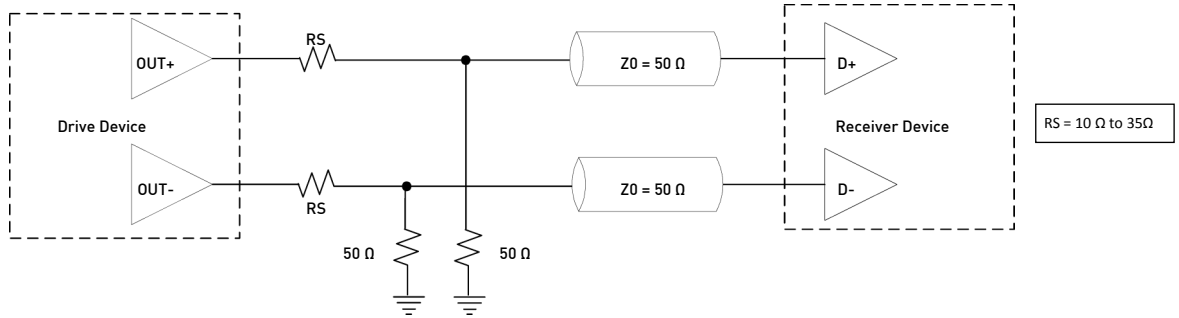

FIGURE 5. LVDS SINGLE TERMINATION (LOAD TERMINATED)

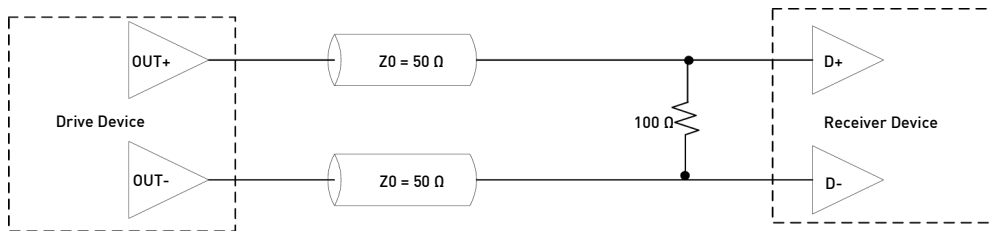
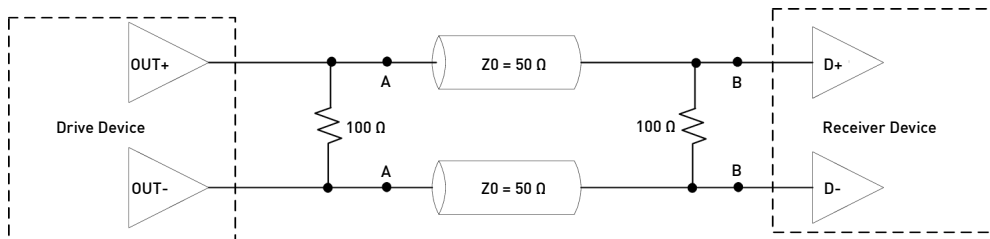

FIGURE 6. LVDS DOUBLE TERMINATION (SOURCE + LOAD TERMINATED)



Note: For AC coupled operation, include/insert decoupling caps at points A or B

TERMINATION DIAGRAMS

FIGURE 7. CML SINGLE LOAD TERMINATION

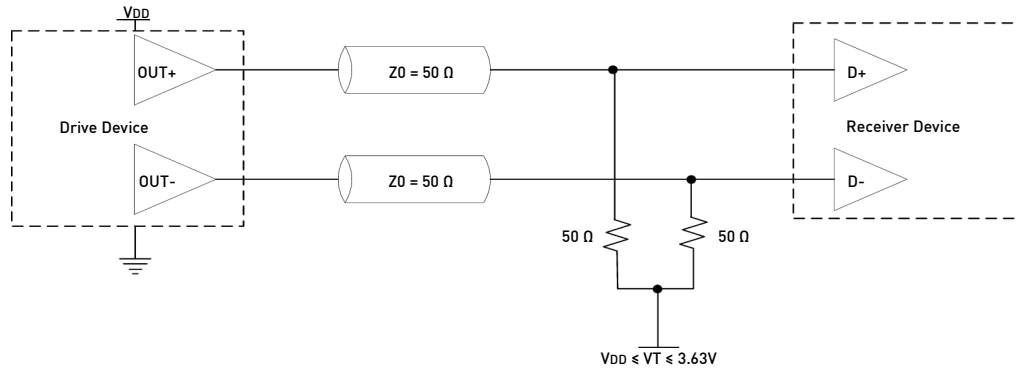
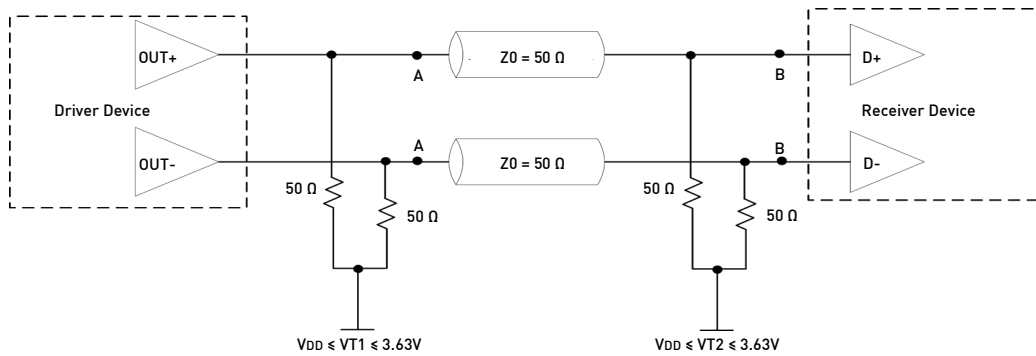

FIGURE 8. CML DOUBLE LOAD TERMINATION



Notes:

1. For DC-coupled operation, $VT1 = VT2$
2. For AC coupled operation, include/insert decoupling caps at points A or B
3. For AC-coupled operation with capacitors placed at point A, $VT2$ sets the input common mode of Receiver Device and need not to be related to $VT1$

DIMENSIONS AND PATTERNS

PACKAGE SIZE – DIMENSIONS (UNIT:MM)

5.0X 3.2 X 0.75 MM

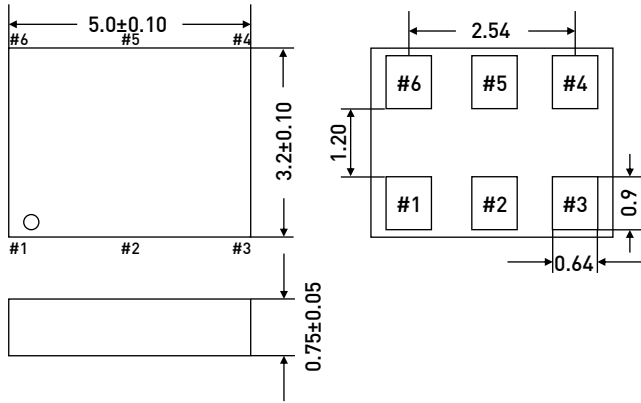

RECOMMENDED LAND PATTERN (UNIT:MM)^[1]

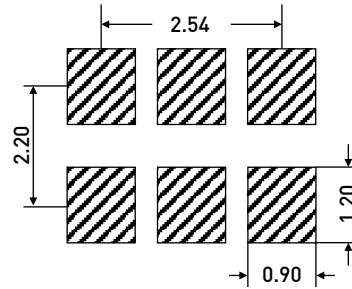

PACKAGE SIZE – DIMENSIONS (UNIT:MM)

7.0X 5.0 X 0.90 MM

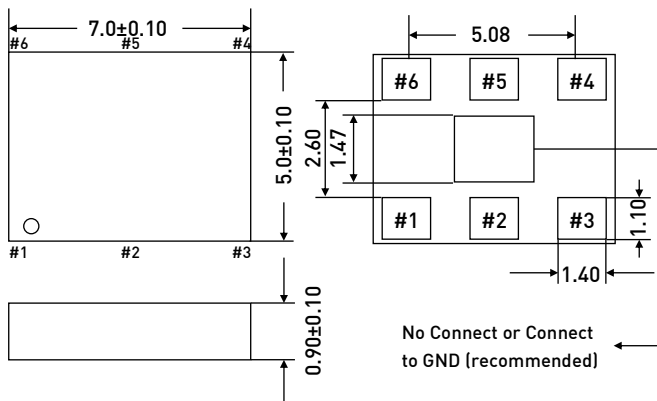

RECOMMENDED LAND PATTERN (UNIT:MM)^[1]

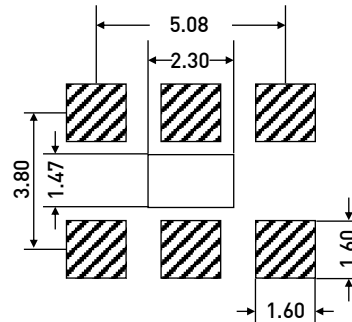

Note:

1. A capacitor value of 0.1 µF between VDD and GND is recommended.

ORDERING INFORMATION

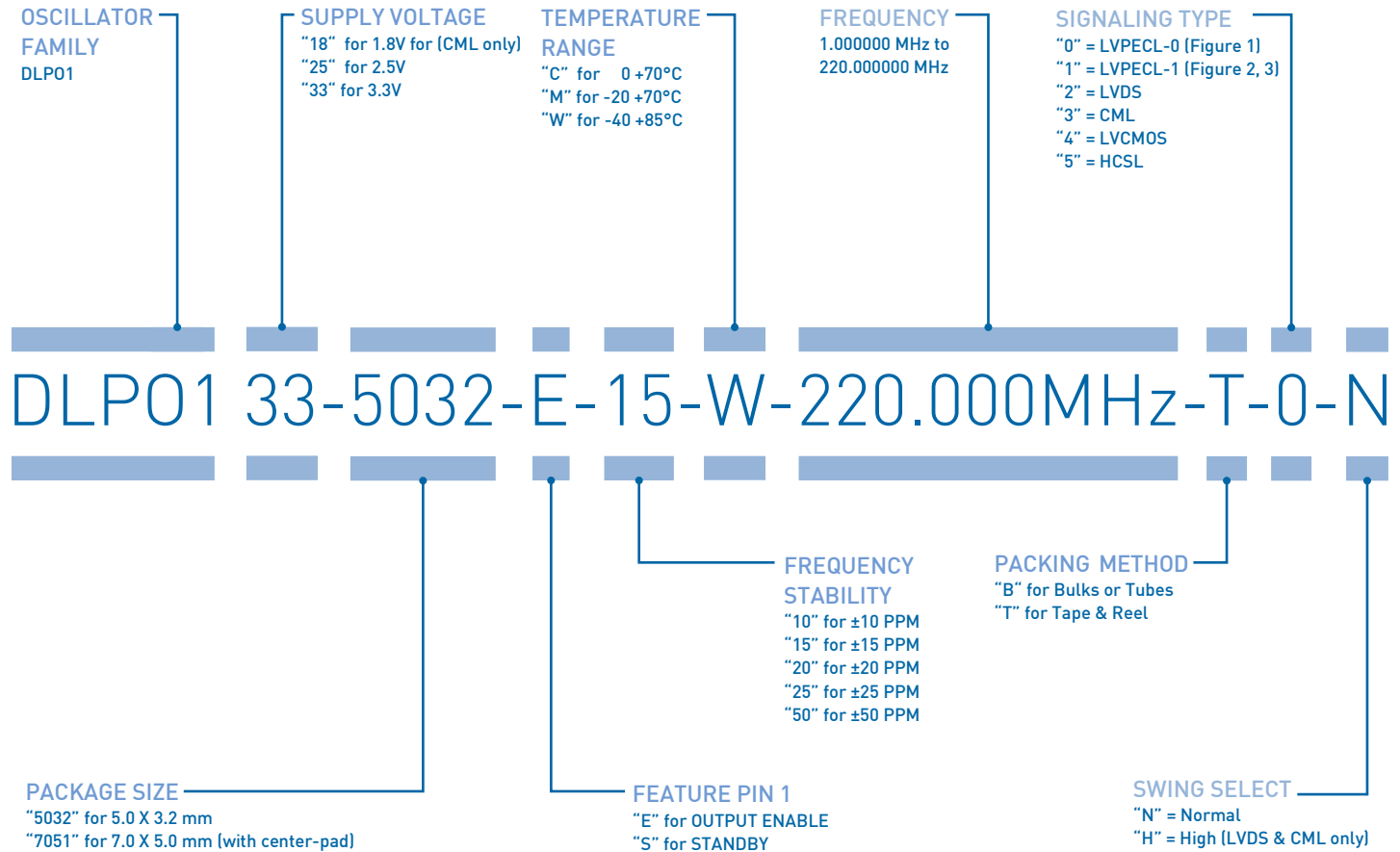

EXAMPLE: DLPO133-5032-E-15-W-220.000MHz-T-0-N

[PLEASE CLICK HERE TO CREATE YOUR OWN ORDERING CODE](#)

SAMPLES ARE AVAILABLE WITHIN A SHORT DELIVERY PERIOD!

FREQUENCY STABILITY VS. TEMPERATURE RANGE OPTIONS

FREQUENCY STABILITY (PPM)	TEMPERATURE RANGE	SUPPLY VOLTAGE		
		1.8 V	2.5 V	3.3 V
±10	C (0 to +70°C)	-	✓	✓
	M (-20 to +70°C)	-	-	-
	W (-40 to +85°C)	-	-	-
±15	C (0 to +70°C)	✓	✓	✓
	M (-20 to +70°C)	-	✓	✓
	W (-40 to +85°C)	-	✓	✓
±20	C (0 to +70°C)	✓	✓	✓
	M (-20 to +70°C)	✓	✓	✓
	W (-40 to +85°C)	✓	✓	✓
±25	C (0 to +70°C)	✓	✓	✓
	M (-20 to +70°C)	✓	✓	✓
	W (-40 to +85°C)	✓	✓	✓
±50	C (0 to +70°C)	✓	✓	✓
	M (-20 to +70°C)	✓	✓	✓
	W (-40 to +85°C)	✓	✓	✓

SIGNALING TYPE VS. SWING SELECT OPTIONS

SIGNALING TYPE	SWING SELECT	SUPPLY VOLTAGE		
		1.8 V	2.5 V	3.3 V
LVPECL-0	Normal	-	✓	✓
	High	-	-	-
LVPECL-1	Normal	-	✓	✓
	High	-	-	-
LVDS	Normal	-	✓	✓
	High	-	✓	✓
CML	Normal	✓	✓	✓
	High	✓	✓	✓
HCSL	Normal	-	✓	✓
	High	-	-	-

REFLOW SOLDER PROFILE

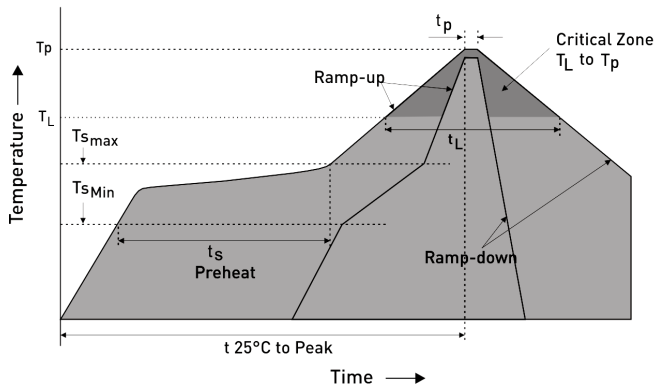

IPC/JEDEC Standard	IPC/JEDEC J-STD-020
Moisture Sensitivity Level	Level 1
TS MAX to TL (Ramp-up Rate)	3°C/second Maximum
Preheat	
- Temperature Minimum (TS MIN)	150°C
- Temperature Typical (TS TYP)	175°C
- Temperature Typical (TS MAX)	200°C
- Time (tS)	60 - 180 Seconds
Ramp-up Rate (TL to TP)	3°C/second Maximum
Time Maintained Above:	
- Temperature (TL)	217°C
- Time (TL)	60 - 150 Seconds
Peak Temperature (TP)	260°C Maximum
Target Peak Temperature (TP Target)	255°C
Time within 5°C of actual peak (tP)	20 - 40 Seconds
Max. Number of Reflow Cycles	3
Ramp-down Rate	6°C/second Maximum
Time 25°C to Peak Temperature (t)	8 minutes Maximum



PREMIUM QUALITY BY PETERMANN-TECHNIK



OUR COMPANY IS CERTIFIED ACCORDING TO ISO 9001:2015 IN OCTOBER 2016 BY THE DMSZ CERTIFIKATION GMBH.

THIS IS FOR YOU TO ENSURE THAT THE PRINCIPLES OF QUALITY MANAGEMENT ARE FULLY IMPLEMENTED IN OUR QUALITY MANAGEMENT SYSTEM AND QUALITY CONTROL METHODS ALSO DOMINATE OUR QUALITY STANDARDS.

© PETERMANN-TECHNIK GmbH 2017. The information contained herein is subject to change at any time without notice. PETERMANN-TECHNIK owns all rights, title and interest to the intellectual property related to PETERMANN-TECHNIK's products, including any software, firmware, copyright, patent, or trademark. The sale of PETERMANN-TECHNIK products does not convey or imply any license under patent or other rights. PETERMANN-TECHNIK retains the copyright and trademark rights in all documents, catalogs and plans supplied pursuant to or ancillary to the sale of products or services by PETERMANN-TECHNIK. Unless otherwise agreed to in writing by PETERMANN-TECHNIK, any reproduction, modification, translation, compilation, or representation of this material shall be strictly prohibited.