

# LOW POWER OSCILLATOR 1.0–110.0 MHz

## SERIES „LPO“

### FEATURES

- + Low Power Oscillator for Low Cost
- + Excellent long time reliability
- + Very tight frequency stability as low as  $\pm 20$  ppm over  $-40/+85^{\circ}\text{C}$
- + Outstanding long term aging
- + Programmable drive strength for improved jitter, system EMI reduction, or driving large capacitive loads
- + LVC MOS/HCMOS compatible output
- + Industry-standard packages: 2.0x1.6; 2.5x2.0; 3.2x2.5; 5.0x3.2; 7.0x5.0
- + Express samples within 1 day ex works PETERMANN-TECHNIK
- + Pb-free, RoHS and REACH compliant / MSL1@260°C

### APPLICATIONS

- + Ideal for DSC, DVC, DVR, IP CAM, Tablets, e-Books, SSD, GPON, EPON, Embedded, Consumer, Medical, Telecom, Industrial, etc.
- + Ideal for high-speed serial protocols such as: USB, SATA, SAS, Firewire, 100M / 1G / 10G Ethernet, etc.

### GENERAL DATA<sup>[1]</sup>

PARAMETER AND CONDITIONS	SYMBOL	MIN.	TYP.	MAX.	UNIT	CONDITION
<b>FREQUENCY RANGE</b>						
Output Frequency Range	f	1	–	110	MHz	
<b>FREQUENCY STABILITY AND AGING</b>						
Frequency Stability	F_stab	-20	–	+20	PPM	Inclusive of initial tolerance at 25°C, 1st year aging at 25°C,
		-25	–	+25	PPM	and variations over operating temperature, rated power
		-50	–	+50	PPM	supply voltage and load (15 pF $\pm$ 10%).
<b>OPERATING TEMPERATURE RANGE</b>						
Operating Temperature Range	T_use	-20	–	+70	°C	Commercial
		-40	–	+85	°C	Industrial
Storage Temperature Range	T_stor	-55	–	+125	°C	Storage
<b>SUPPLY VOLTAGE AND CURRENT CONSUMPTION</b>						
Supply Voltage	V <sub>DD</sub>	1.62	1.8	1.98	V	Contact Petermann-Technik for 1.5V support
		2.25	2.5	2.75	V	
		2.52	2.8	3.08	V	
		2.7	3.0	3.3	V	
		2.97	3.3	3.63	V	
		2.25	–	3.63	V	
Current Consumption	I <sub>DD</sub>	–	3.8	4.5	mA	No load condition, f = 20 MHz, V <sub>DD</sub> = 2.8V, 3.0V, 3.3V, 2.25V to 3.63V
		–	3.6	4.2	mA	No load condition, f = 20 MHz, V <sub>DD</sub> = 2.5V
		–	3.4	3.9	mA	No load condition, f = 20 MHz, V <sub>DD</sub> = 1.8V
OE Disable Current	I <sub>OD</sub>	–	–	4	mA	V <sub>DD</sub> = 2.5V to 3.3V, OE = GND, output is pulled down
		–	–	3.8	mA	V <sub>DD</sub> = 1.8V, OE = GND, output is pulled down
Standby Current	I <sub>std</sub>	–	2.6	4.3	μA	ST = GND, V <sub>DD</sub> = 2.8V to 3.3V, output is pulled down
		–	1.4	2.5	μA	ST = GND, V <sub>DD</sub> = 2.5V, output is pulled down
		–	0.6	1.3	μA	ST = GND, V <sub>DD</sub> = 1.8V, output is pulled down

Note: 1. All electrical specifications in the above table are specified with 15 pF output load at default drive strength and for all V<sub>DD</sub>(s) unless otherwise stated.

## GENERAL DATA<sup>[1]</sup> (continued)

PARAMETER AND CONDITIONS	SYMBOL	MIN.	TYP.	MAX.	UNIT	CONDITION
<b>LVC MOS OUTPUT CHARACTERISTICS</b>						
Duty Cycle	DC	45	-	55	%	All V <sub>DD</sub> s
Rise/Fall Time	Tr, Tf	-	1	2	ns	V <sub>DD</sub> = 2.5V, 2.8V, 3.0V or 3.3V, 20% - 80%
		-	1.3	2.5	ns	V <sub>DD</sub> = 1.8V, 20% - 80%
		-	-	2	ns	V <sub>DD</sub> = 2.25V - 3.63V, 20% - 80%
Output High Voltage	VOH	90%	-	-	V <sub>DD</sub>	IOH = -4 mA (V <sub>DD</sub> = 3.0V or 3.3V) IOH = -3 mA (V <sub>DD</sub> = 2.8V and V <sub>DD</sub> = 2.5V) IOH = -2 mA (V <sub>DD</sub> = 1.8V)
Output Low Voltage	VOL	-	-	10%	V <sub>DD</sub>	IOL = 4 mA (V <sub>DD</sub> = 3.0V or 3.3V) IOL = 3 mA (V <sub>DD</sub> = 2.8V and V <sub>DD</sub> = 2.5V) IOL = 2 mA (V <sub>DD</sub> = 1.8V)
<b>INPUT CHARACTERISTICS</b>						
Input High Voltage	VIH	70%	-	-	V <sub>DD</sub>	Pin 1, OE or ST
Input Low Voltage	VIL	-	-	30%	V <sub>DD</sub>	Pin 1, OE or ST
Input Pull-up Impedance	Z <sub>in</sub>	-	87	100	kΩ	Pin 1, OE logic high or logic low, or ST logic high
		2	-	-	MΩ	Pin 1, ST logic low
<b>STARTUP AND RESUME TIMING</b>						
Startup Time	T <sub>start</sub>	-	-	5	ms	Measured from the time V <sub>DD</sub> reaches its rated minimum value
Enable/Disable Time	T <sub>oe</sub>	-	-	130	ns	f = 110 MHz. For other frequencies, T <sub>oe</sub> = 100 ns + 3* cycles
Resume Time	T <sub>resume</sub>	-	-	5	ms	Measured from the time ST pin crosses 50% threshold
<b>JITTER</b>						
RMS Period Jitter	T <sub>jitt</sub>	-	1.76	3	ps	f = 75 MHz, V <sub>DD</sub> = 2.5V, 2.8V, 3.0V or 3.3V
		-	1.78	3	ps	f = 75 MHz, V <sub>DD</sub> = 1.8V
RMS Phase Jitter (random)	T <sub>phj</sub>	-	0.5	0.9	ps	f = 75 MHz, Integration bandwidth = 900 kHz to 7.5 MHz
		-	1.3	2	ps	f = 75 MHz, Integration bandwidth = 12 kHz to 20 MHz
<b>EXCELLENT RELIABILITY DATA</b>						
MTBF						500 million hours
Shock Resistance:						10.000 G
Vibration Resistance:						70 g

Note: 1. All electrical specifications in the above table are specified with 15 pF output load and for all V<sub>DD</sub>(s) unless otherwise stated.

## PIN DESCRIPTION

PIN	SYMBOL	FUNCTIONALITY
1	OE/ST/NC	Output Enable H or Open <sup>[2]</sup> : specified frequency output L: output is high impedance. Only output driver is disabled.
		Standby H or Open <sup>[2]</sup> : specified frequency output L: output is low (weak pull down). Device goes to sleep mode. Supply current reduces to I <sub>std</sub> .
		No Connect Any voltage between 0 and V <sub>DD</sub> or Open <sup>[2]</sup> : Specified frequency output. Pin 1 has no function.
2	GND	Power Electrical ground <sup>[3]</sup>
3	OUT	Output Oscillator output
4	V <sub>DD</sub>	Power Power supply voltage <sup>[3]</sup>

## TOP VIEW

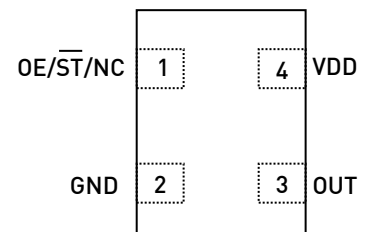

Note: 2. In OE or ST mode, a pull-up resistor of 10kΩ or less is recommended if pin 1 is not externally driven. If pin 1 needs to be left floating, use the NC option.

3. A capacitor value of 0.1 μF between V<sub>DD</sub> and GND is recommended.

## TEST CIRCUIT AND WAVEFORM

FIGURE 1. TEST CIRCUIT

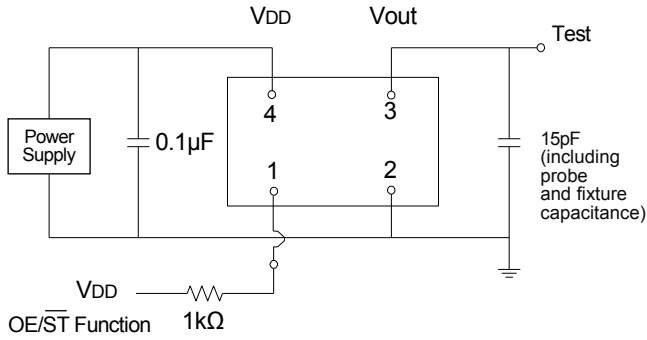
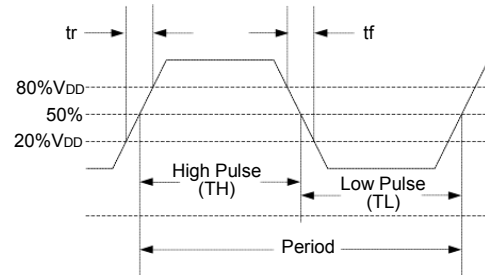

FIGURE 2. WAVEFORM



## TIMING DIAGRAMS<sup>(4)</sup>

FIGURE 3. STARTUP TIMING (OE/ST MODE)

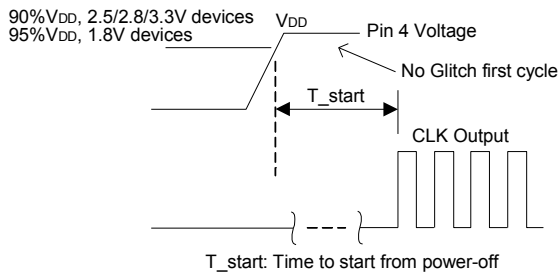

FIGURE 4. STANDBY RESUME TIMING (ST MODE ONLY)

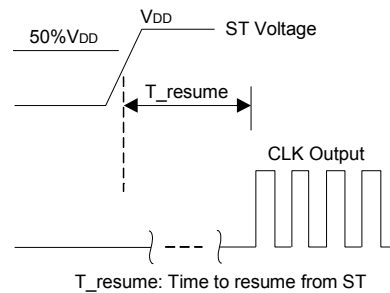

FIGURE 5. OE ENABLE TIMING (OE MODE ONLY)

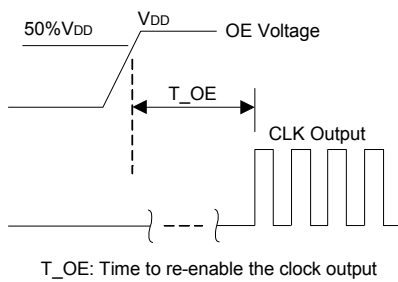
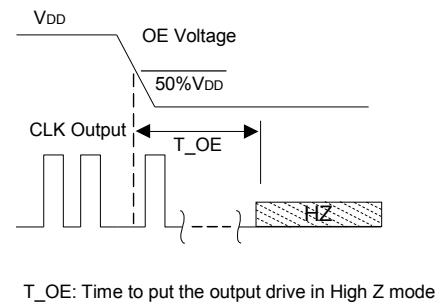

FIGURE 6. OE DISABLE TIMING (OE MODE ONLY)



Note: 4. LPO supports no runt pulses and no glitches during startup or resume.

## PERFORMANCE PLOTS<sup>[5]</sup>

FIGURE 7. IDD vs. FREQUENCY

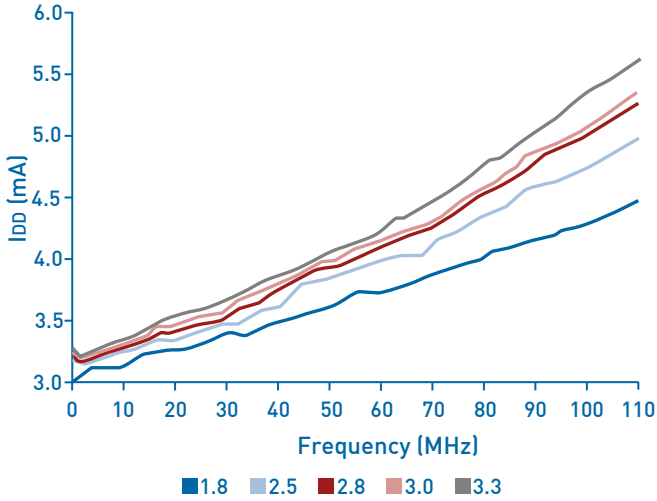

FIGURE 8. RMS PERIOD JITTER vs. FREQUENCY

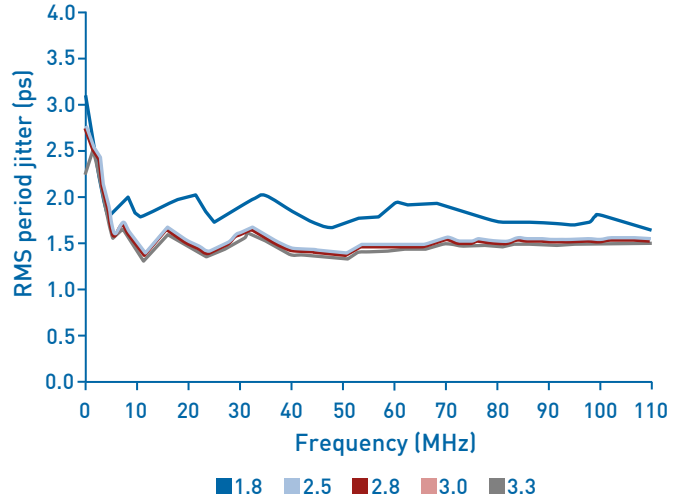

FIGURE 9. RMS PHASE JITTER vs. FREQUENCY  
 (12 kHz TO 20 MHz INTEGRATION BANDWIDTH)

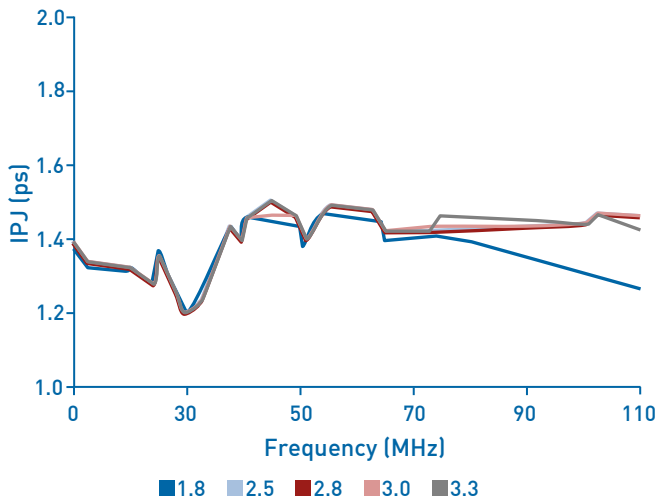

FIGURE 10. RMS PHASE JITTER vs. FREQUENCY  
 (900 kHz TO 20 MHz INTEGRATION BANDWIDTH)

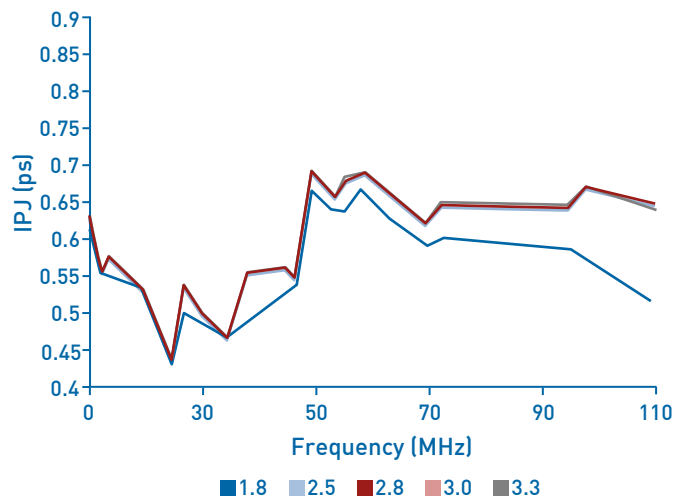

FIGURE 11. DUTY CYCLE vs. FREQUENCY

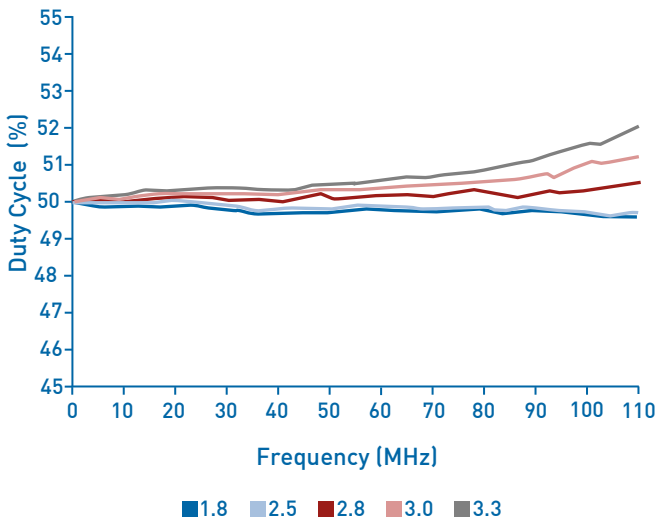
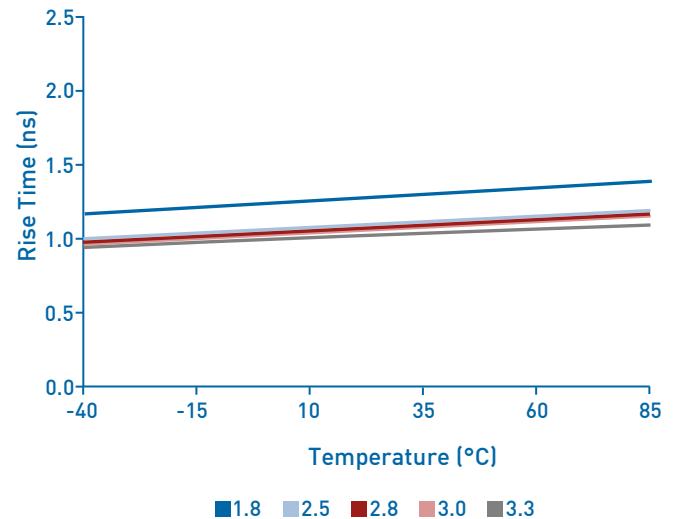

FIGURE 12. RISE TIME vs. TEMPERATURE, 20 MHz OUTPUT



Note: 5. All plots are measured with 15 pF load at room temperature, unless otherwise stated.

## PROGRAMMABLE DRIVE STRENGTH

The LPO includes a programmable drive strength feature named Soft-Level to provide a simple, flexible tool to optimize the clock rise/fall time for specific applications. Benefits from the programmable drive strength feature are:

- + Improves system radiated electromagnetic interference (EMI) by slowing down the clock rise/fall time
- + Improves the downstream clock receiver's (RX) jitter by decreasing (speeding up) the clock rise/fall time.
- + Ability to drive large capacitive loads while maintaining full swing with sharp edge rates.

For more detailed information about rise/fall time control and drive strength selection, see the Petermann-Technik Applications Note section: <http://www.petermann-technik.com>

### EMI REDUCTION BY SLOWING RISE/FALL TIME (SoftLevel FUNCTION)

Figure 13 shows the harmonic power reduction as the rise/fall times are increased (slowed down). The rise/fall times are expressed as a ratio of the clock period. For the ratio of 0.05, the signal is very close to a square wave. For the ratio of 0.45, the rise/fall times are very close to near-triangular waveform. These results, for example, show that the 11th clock harmonic can be reduced by 35 dB if the rise/fall edge is increased from 5% of the period to 45% of the period.

FIGURE 13. HARMONIC EMI REDUCTION AS A FUNCTION OF SLOWER RISE/FALL TIME (SoftLevel FUNCTION)

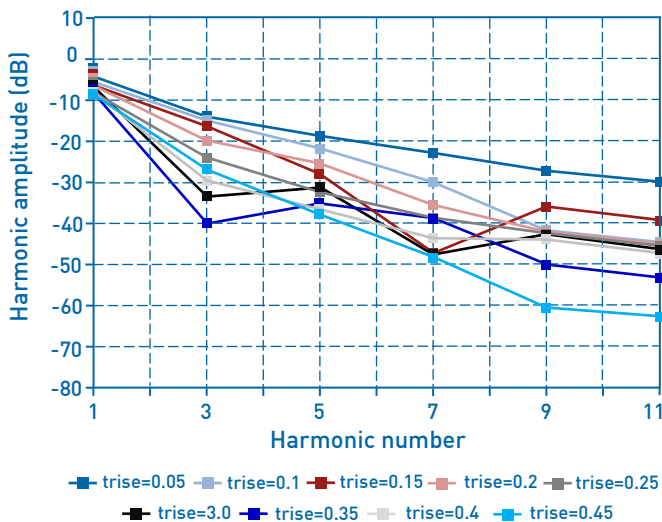

### JITTER REDUCTION WITH FASTER RISE/FALL TIME

Power supply noise can be a source of jitter for the downstream chipset. One way to reduce this jitter is to increase rise/fall time (edge rate) of the input clock. Some chipsets would require faster rise/fall time in order to reduce their sensitivity to this type of jitter. The LPO provides up to 3 additional high drive strength settings for very fast rise/fall time. Refer to the rise/fall time tables to determine the proper drive strength.

### HIGH OUTPUT LOAD CAPABILITY

The rise/fall time of the input clock varies as a function of the actual capacitive load the clock drives. At any given drive strength, the rise/fall time becomes slower as the output load increases. As an example, for a 3.3V LPO device with default drive strength setting, the typical rise/fall time is 1ns for 15 pF output load. The typical rise/fall time slows down to 2.6 ns when the output load increases to 45 pF. One can choose to speed up the rise/fall time to 1.68 ns by then increasing the drive strength setting on the LPO.

The LPO can support up to 60 pF or higher in maximum capacitive loads with up to 3 additional drive strength settings. Refer to the Rise/Fall Time Tables to determine the proper drive strength for the desired combination of output load vs. rise/fall time.

### LPO DRIVE STRENGTH SELECTION

Tables 1 through 5 define the rise/fall time for a given capacitive load and supply voltage.

1. Select the table that matches the LPO nominal supply voltage (1.8V, 2.5V, 2.8V, 3.0V, 3.3V).
2. Select the capacitive load column that matches the application requirement (5 pF to 60 pF)
3. Under the capacitive load column, select the desired rise/fall times.
4. The left-most column represents the part number code for the corresponding drive strength.
5. Add the drive strength code to the part number for ordering purposes.

### CALCULATING MAXIMUM FREQUENCY

Based on the rise and fall time data given in Tables 1 through 5, the maximum frequency the oscillator can operate with guaranteed full swing of the output voltage over temperature as follows:

$$\text{Max. frequency} = \frac{1}{6 \times (\text{Trise})}$$

### EXAMPLE 1

Calculate  $f_{\text{MAX}}$  for the following condition:

- + VDD = 1.8V (Table 1)
- + Capacitive Load: 30pF
- + Desired Tr/tf time = 3ns (rise/fall time part number code=E)

Part number for the above example:

LPO18-2520-E-25-M-25.000MHz-T-E

Drive strength code is inserted here. Standard setting is "S"

## RISE/FALL TIME (20% TO 80%) vs C<sub>LOAD</sub>

TABLE 1. VDD = 1.8V RISE/FALL TIMES FOR SPECIFIC C<sub>LOAD</sub>

Drive Strength \ C <sub>LOAD</sub>	RISE/FALL TIME TYP (NS)				
	5 pF	15 pF	30 pF	45 pF	60 pF
L	6.16	11.61	22.00	31.27	39.91
A	3.19	6.35	11.00	16.01	21.52
R	2.11	4.31	7.65	10.77	14.47
B	1.65	3.23	5.79	8.18	11.08
T	0.93	1.91	3.32	4.66	6.48
E	0.78	1.66	2.94	4.09	5.74
U	0.70	1.48	2.64	3.68	5.09
S = standard limit	0.65	1.30	2.40	3.35	4.56

TABLE 2. VDD = 2.5V RISE/FALL TIMES FOR SPECIFIC C<sub>LOAD</sub>

Drive Strength \ C <sub>LOAD</sub>	RISE/FALL TIME TYP (NS)				
	5 pF	15 pF	30 pF	45 pF	60 pF
L	4.13	8.25	12.82	21.45	27.79
A	2.11	4.27	7.64	11.20	14.49
R	1.45	2.81	5.16	7.65	9.88
B	1.09	2.20	3.88	5.86	7.57
T	0.62	1.28	2.27	3.51	4.45
S = standard limit	0.54	1.00	2.01	3.10	4.01
U	0.43	0.96	1.81	2.79	3.65
F	0.34	0.88	1.64	2.54	3.32

TABLE 3. VDD = 2.8V RISE/FALL TIMES FOR SPECIFIC C<sub>LOAD</sub>

Drive Strength \ C <sub>LOAD</sub>	RISE/FALL TIME TYP (NS)				
	5 pF	15 pF	30 pF	45 pF	60 pF
L	3.77	7.54	12.28	19.57	25.27
A	1.94	3.90	7.03	10.24	13.34
R	1.29	2.57	4.72	7.01	9.06
B	0.97	2.00	3.54	5.43	6.93
T	0.55	1.12	2.08	3.22	4.08
S = standard limit	0.44	1.00	1.83	2.82	3.67
U	0.34	0.88	1.64	2.52	3.30
F	0.29	0.81	1.48	2.29	2.99

TABLE 4. VDD = 3.0V RISE/FALL TIMES FOR SPECIFIC C<sub>LOAD</sub>

Drive Strength \ C <sub>LOAD</sub>	RISE/FALL TIME TYP (NS)				
	5 pF	15 pF	30 pF	45 pF	60 pF
L	3.60	7.21	11.97	18.74	24.30
A	1.84	3.71	6.72	9.86	12.68
R	1.22	2.46	4.54	6.76	8.62
B	0.89	1.92	3.39	5.20	6.64
S = standard limit	0.51	1.00	1.97	3.07	3.90
E	0.38	0.92	1.72	2.71	3.51
U	0.30	0.83	1.55	2.40	3.13
F	0.27	0.76	1.39	2.16	2.85

TABLE 5. VDD = 3.3V RISE/FALL TIMES FOR SPECIFIC C<sub>LOAD</sub>

Drive Strength \ C <sub>LOAD</sub>	RISE/FALL TIME TYP (NS)				
	5 pF	15 pF	30 pF	45 pF	60 pF
L	3.39	6.88	11.63	17.56	23.59
A	1.74	3.50	6.38	8.98	12.19
R	1.16	2.33	4.29	6.04	8.34
B	0.81	1.82	3.22	4.52	6.33
S = standard limit	0.46	1.00	1.86	2.60	3.84
E	0.33	0.87	1.64	2.30	3.35
U	0.28	0.79	1.46	2.05	2.93
F	0.25	0.72	1.31	1.83	2.61

## DIMENSIONS AND PATTERNS

### PACKAGE SIZE - DIMENSIONS (UNIT:MM)

2.0 X 1.6 X 0.75 MM

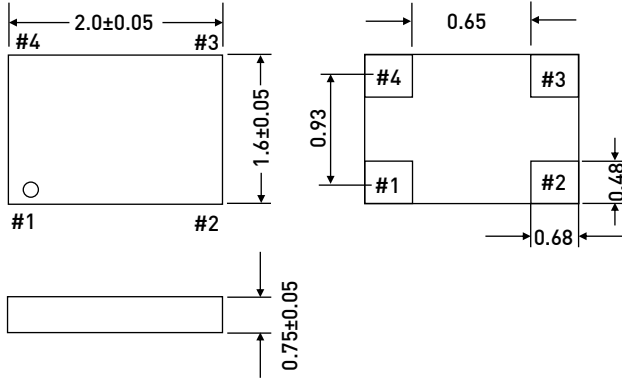

### RECOMMENDED LAND PATTERN (UNIT:MM)<sup>[6]</sup>

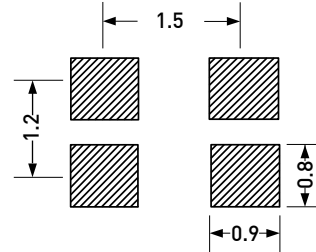

### PACKAGE SIZE - DIMENSIONS (UNIT:MM)

2.5 X 2.0 X 0.75 MM

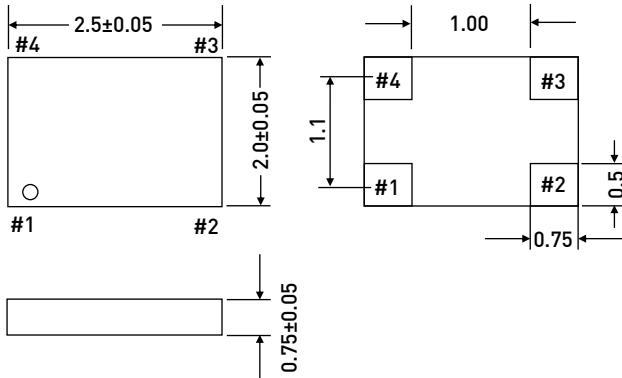

### RECOMMENDED LAND PATTERN (UNIT:MM)

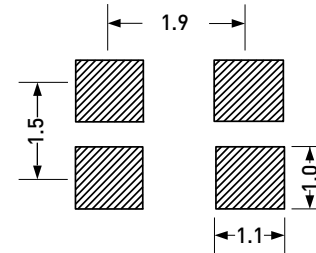

### PACKAGE SIZE - DIMENSIONS (UNIT:MM)

3.2 X 2.5 X 0.75 MM

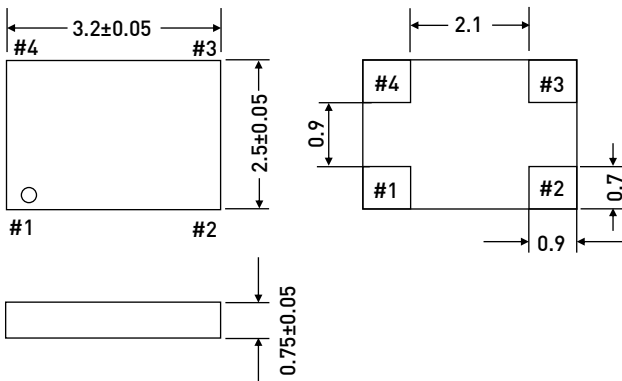

### RECOMMENDED LAND PATTERN (UNIT:MM)

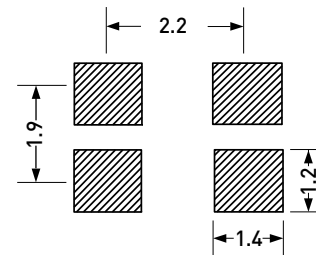

Note: 6. A capacitor value of 0.1 µF between V<sub>DD</sub> and GND is recommended (see note 2 + 3).

## DIMENSIONS AND PATTERNS

### PACKAGE SIZE – DIMENSIONS (UNIT:MM)

5.0 X 3.2 X 0.75 MM

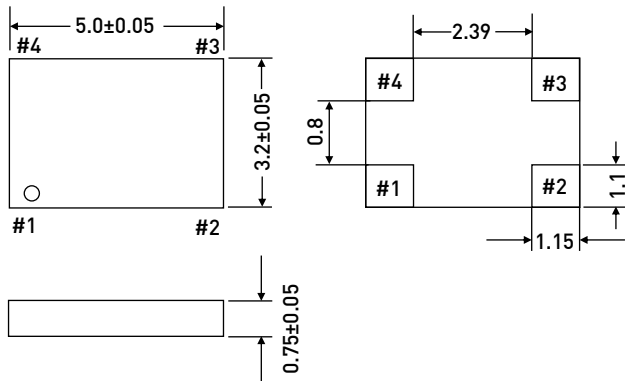

### RECOMMENDED LAND PATTERN (UNIT:MM)<sup>[7]</sup>

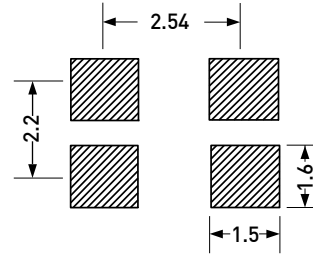

### PACKAGE SIZE – DIMENSIONS (UNIT:MM)

7.0 X 5.0 X 0.90 MM

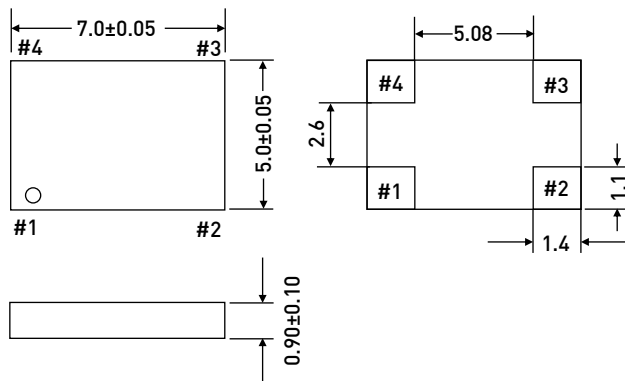

### RECOMMENDED LAND PATTERN (UNIT:MM)

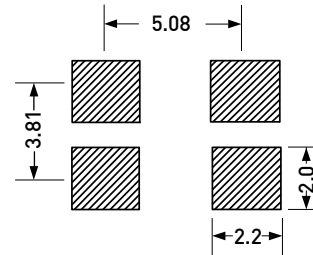

### REFLOW SOLDER PROFILE

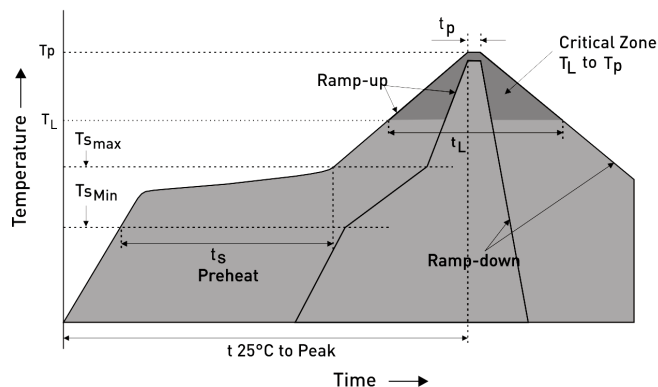

IPC/JEDEC Standard	IPC/JEDEC J-STD-020
Moisture Sensitivity Level	Level 1
TS MAX to TL (Ramp-up Rate)	3°C/second Maximum
Preheat	
- Temperature Minimum (TS MIN)	150°C
- Temperature Typical (TS TYP)	175°C
- Temperature Typical (TS MAX)	200°C
- Time (tS)	60 - 180 Seconds
Ramp-up Rate (TL to TP)	3°C/second Maximum
Time Maintained Above:	
- Temperature (TL)	217°C
- Time (TL)	60 - 150 Seconds
Peak Temperature (TP)	260°C Maximum
Target Peak Temperature (TP Target)	255°C
Time within 5°C of actual peak (tP)	20 - 40 Seconds
Max. Number of Reflow Cycles	3
Ramp-down Rate	6°C/second Maximum
Time 25°C to Peak Temperature (t)	8 minutes Maximum

**Note: 7.** A capacitor value of 0.1  $\mu$ F between  $V_{DD}$  and GND is recommended (see note 2 + 3).



## ORDERING INFORMATION

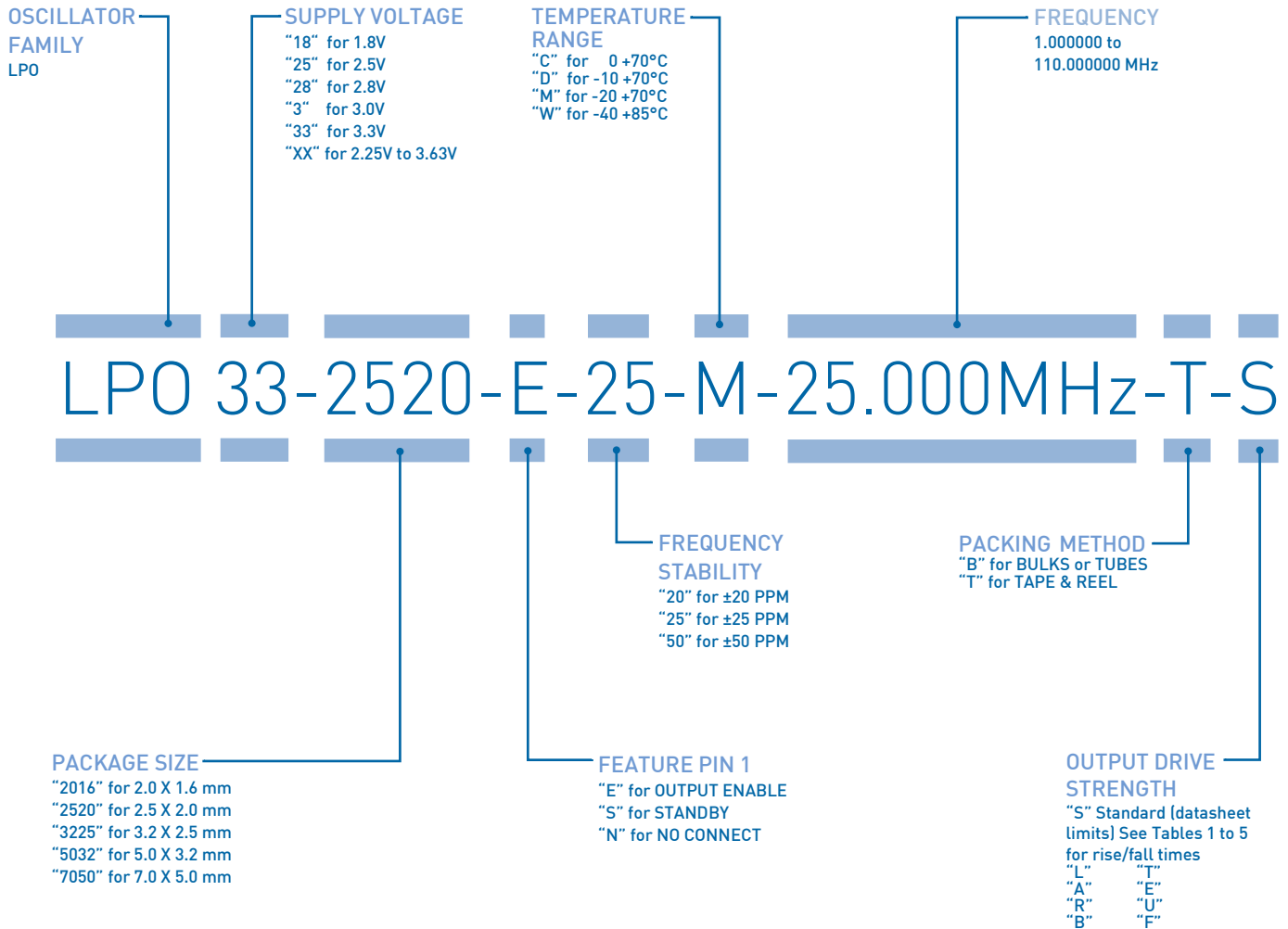

EXAMPLE: LPO33-2520-E-25-M-25.000MHz-T-S

[PLEASE CLICK HERE TO CREATE YOUR OWN ORDERING CODE](#)

**EXPRESS SAMPLES ARE DELIVERABLE ON THE SAME DAY IF ORDERED UNTIL 02:00 PM!**



## PREMIUM QUALITY BY PETERMANN-TECHNIK



OUR COMPANY IS CERTIFIED ACCORDING TO ISO 9001:2015 IN OCTOBER 2016 BY THE DMSZ CERTIFIKATION GMBH.

THIS IS FOR YOU TO ENSURE THAT THE PRINCIPLES OF QUALITY MANAGEMENT ARE FULLY IMPLEMENTED IN OUR QUALITY MANAGEMENT SYSTEM AND QUALITY CONTROL METHODS ALSO DOMINATE OUR QUALITY STANDARDS.